

**BILANT TERITORIAL PROPRIETATE BENEFICIAR**

ZONE FUNCTIONALE	EXISTENT		PROPUS	
	S mp	% din total	S mp	% din total
ZONA LOCUINTE SI FUNCTIUNI COMPLEM.	-	-	950	11.91
TEREN ARABIL	7024	88.09	-	-
ZONA DRUM	-	-	-	-
ZONA INSTITUTII SI SERVICII/ MICA PRODUCTIE	-	-	-	-
ZONA SPATII VERZI	-	-	235	2.95
<b>TOTAL</b>	<b>7024</b>	<b>88.09</b>	<b>950</b>	<b>11.91</b>
<b>TOTAL PROPRIETATE</b>	<b>7974</b>	<b>100</b>	<b>7974</b>	<b>100</b>

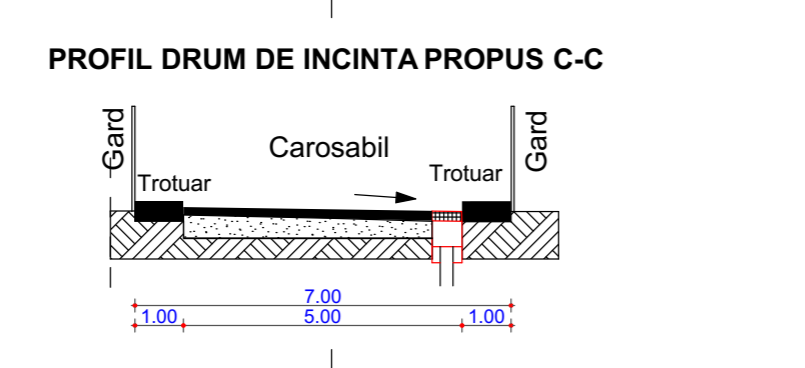
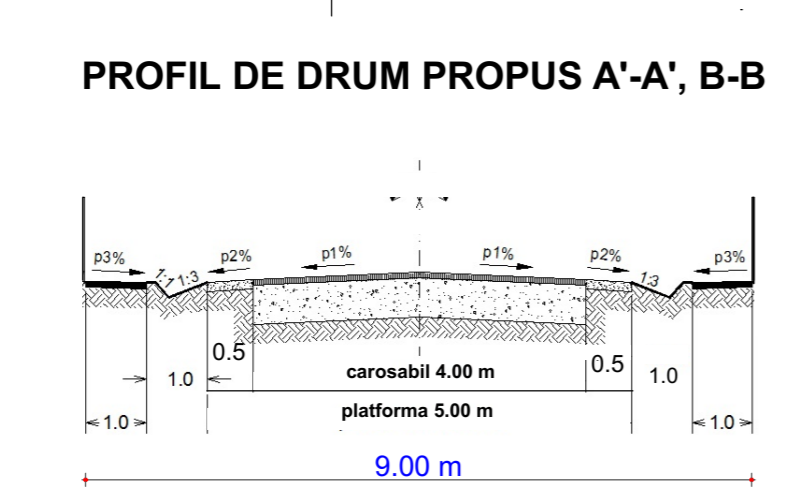
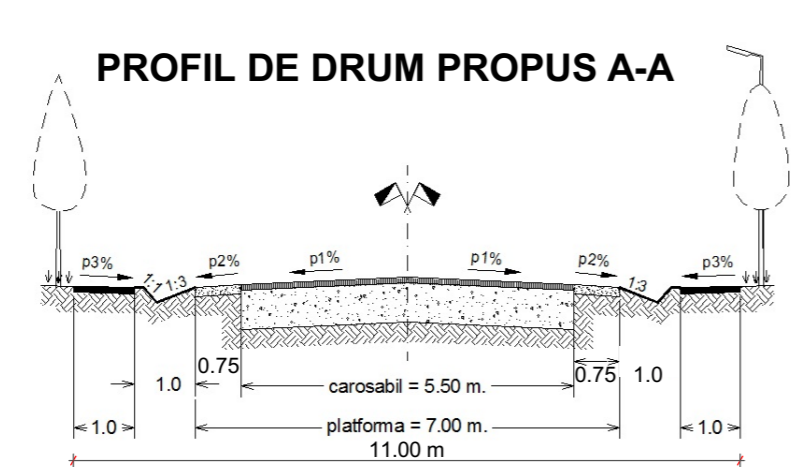

- LEGENDA**
- LIMITE**
    - LIMITA PROPRIETATE STUDIATA
    - LIMITA INTRAVILAN PROPUS
  - ZONIFICARE FUNCTIONALA**
    - ZONA TEREN ARABIL IN EXTRAVILAN MENTINUTA
    - ZONA LOCUINTE SI FUNCTIUNI COMPLEMENTARE EXIST. SI EXTINSA
    - ZONA MIXTA INSTITUTII SI SERVICII/MICA PRODUCTIE PROPUSA
    - ZONA SPATII VERZI PROPUSA
  - DRUMURI**
    - DRUMURI PROPUSE
    - TROTUARE PROPUSE
    - PLATFORMA ACCES SI PARCARE PROPUSA
  - CONSTRUCTII EXISTENTE**
  - REGIM DE ALINIERE PROPUS**
  - IMPREJMUIRE PROPUSA**
  - EDIFICABIL MAXIM (SUPRAFATA IN CARE SE POATE CONSTRUI CU RESPECTAREA P.O.T. SI A CODULUI CIVIL)**
  - ZONA DE PROTECTIE SANITARA CONFORM ORD. 119/2014 AL MINISTERULUI SANATATII**

**INDICI URBANISTICI**  
 ZONA LOCUINTE  
 P.O.T. max. propus = 35%  
 C.U.T. max. propus = 1,0  
 INALTIME MAXIMA PROPUSA  
 Hmax = P+1+M  
 INDICI URBANISTICI  
 INSTITUTII SI SERVICII/MICA PRODUCTIE  
 P.O.T. max. propus = 50%  
 C.U.T. max. propus = 1,0  
 INALTIME MAXIMA PROPUSA  
 Hmax = P+1

PROIECT P.U.Z. LOCUINTE UNIFAMILIALE, SERVICE AUTO SI IMPREJMUIRE TEREN  
 NR. PROIECT 4/2016  
 AMPLASAMENT SAT SCHINENI, COMUNA SAUCESTI, JUD. BACAU  
 BENEFICIAR PORUMBU GEANY-CRISTINEL SI PORUMBU ANCA-MIHAELA  
 PROIECTANT GENERAL Arh. Catrinel Letter  
 Dovada de inregistrare nr. 67/2006 C.I.F. 19546799 BACAU, B-dul Unirii, nr. 11  
 PROIECTANT DE SPECIALITATE Arh. Catrinel Letter  
 VERIFICATOR CERINTA CALITATE REFERATE/EXPERTIZA NR. DATA SEMNATURA  
 REPROIECT Arh. Catrinel Letter  
 PROIECT Arh. Catrinel Letter  
 VERIFICATOR Arh. Catrinel Letter  
 FAZA DOC. DATA 10.2016 ANIZE SCARA 1:500  
 TITLU PLANSA PLANSA U2  
 REGLEMENTARI ZONIFICARE FUNCTIONALA REVIZIE rev A